

# THE PERFECT SOLUTION

## ATMOSEAL®

FRAME IS MADE  
OF GALVANIZED  
STEEL CHANNEL  
AND  
PRESSURE  
TREATED WOOD



FLEXIBLE  
AND  
RETRACTABLE



QUICK AND EASY  
INSTALLATION



HIGH  
PERFORMANCE  
VINYL



CUSTOMER UNITS  
AVAILABLE



LONG LASTING  
AND  
LOW MAINTENANCE



## SERIES 0501 RETRACTABLE TRUCK SHELTER

Designed for door openings up to 10'W x 10'H, the Series 0501 is designed to retract upon impact. The 0501's collapsible scissor arms are spring loaded, keeping the shelter in a projected position. When compressed by an incoming trailer the panels create an air tight seal. The series 0501 is very effective where the driveway approach is difficult. The series 0501 creates a tight seal that blocks out foul weather, insects, dust and dirt, while saving money on energy costs. A large selection of tough abrasion resistant fabrics makes this unit an excellent long lasting investment. Truck shelters help productivity by increasing safety, protecting personnel, products and equipment.

# SUPER SEAL

Tel: 905.850.2929 Tel: 1.800.337.3239  
Fax: 905.850.2922 Fax: 905.850.4440

[www.supersealmfg.com](http://www.supersealmfg.com)

SuperSeal Mfg. Ltd.  
670 Rowntree Dairy Rd.,  
Woodbridge, Ontario, Canada L4L 5T8

## SPECIFICATIONS

### Series 0501 Product Details:

- Series 0501 standard dimensions for door openings 10'W x 10'H are 11'6"W x 11'H (O.D.) x 24" projection with 21" wide vertical panels and a 36" drop header panel.
- Seals trailers from 11'6" to 13'6" high from grade with a dock height of 48". Also seals trailers with widths from 8'W.
- A larger selection of cover fabrics are available, including our exclusive SS-90 high performance vinyl. Other fabrics also include hypalon and vinyls.
- Can be designed to suit a large variety of oversized door openings, heights, widths and/or dock projections.
- 18"-20" projection in front of the dock bumper face is recommended to provide a proper seal.

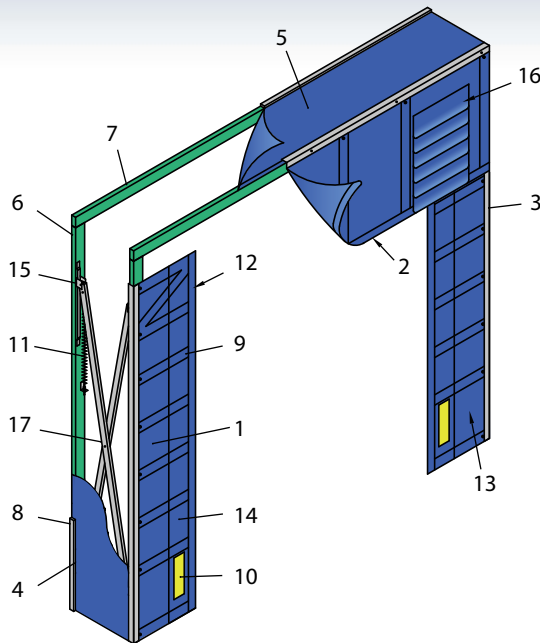

1. Vertical Panels
2. Header Panel
3. Angle Trim
4. "U" Bracket
5. Perimeter Fabric
6. 2" x 4" Vertical Pressure Treated Wood Frame
7. 2" x 4" Header Pressure Treated Wood Frame
8. Trim
9. Fiberglass Stays
10. 4" Yellow Guide Stripe
11. Spring
12. Foam Bead
13. Cover fabric
14. Double Ply of Fabric on Impact Area
15. Sliding Bracket
16. Protective Flaps
17. Scissor Extension Arm

### Specifications:

Retractable truck dock shelter(s) to be Series 0501 as manufactured by Super Seal Mfg. Ltd., Woodbridge, Ontario. Retractable truck dock shelter(s) to be manufactured to fit door opening size(s) \_\_\_\_ft. wide x \_\_\_\_ft. high. Mounting backboard frame to be constructed of top grade pressure treated wood. The front pressure treated frame is to be housed in a formed steel "U" channel for strength and rigidity. All steel components to be galvanized to resist corrosion. Scissor arms made from galvanized steel tubing are spring loaded to yield under misdirected or abnormal pressure. The vertical panels shall contain fiberglass stays, the top three (3) being in a "Z" pattern to keep the curtain straight at all times. Vertical panels have a double layer of fabric at the leading edge impact area and a 4" wide x 14" high yellow guide stripe to aide in spotting trailers. The header panel to have full height fiberglass stays and overlapping protective flaps at trailer impact areas. The header panel to have elastic wind straps to keep the panel in position. All stay to be enclosed in multi-layer reinforcement pockets. Leading edges of vertical and header panels to have a sewn in foam bead for a tight seal. Double stitched, high strength twisted 4 ply 100% polyester bonded thread U.V. treated used for sewing throughout. All exterior front frame corners shall be trimmed with angle to provide a neat, clean finish. Unit shall be furnished with all necessary mounting hardware, galvanized to resist corrosion.

### Options:

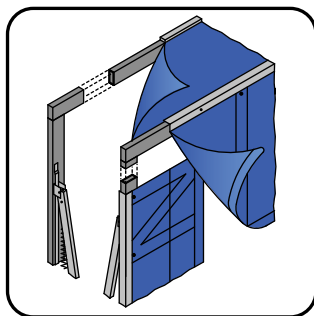

Tubular Steel Frame

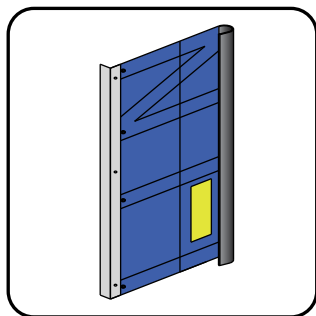

Super Snug

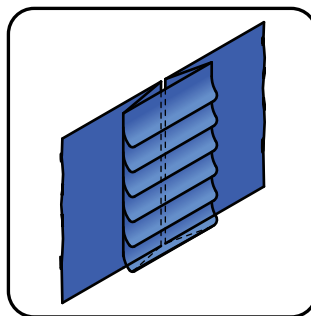

Super Split Protective Flaps

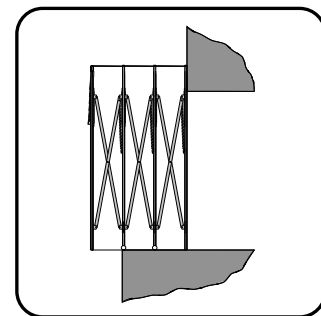

Extended Projections

**Wider And Higher Units Are Also Available.**



DEALER IMPRINT

\*\* All Super Seal products are subject to design modifications without notice. Product may be shown with non-standard options.

