

THE PERFECT SOLUTION

ATMOSEAL®

Adjustable curtain for trailers with varied height.

Custom sized to insure a perfect seal.

Backing is made with the highest quality pressure treated wood.

Yellow guide stripe is vulcanized (heat sealed); not sewn.

Long lasting and low maintenance.



Adjustable "split" curtain is an available option.

Extra long lasting, high quality vinyl with U.V. stabilizer to prevent fading and cracking.

Specially selected, high density memory foam reduces damage by compressing on all sides.

Galvanized steel mounting brackets.

SERIES 0201

ADJUSTABLE CURTAIN DOCK SEAL

Designed to work best where doors are over 9'H and or where trailers vary in height, the 0201 is an economical way to form an air tight seal between the building and trailer for dock openings up to 10' W x 12' H. For added versatility the 0201 is also available with adjustable head curtain that can be easily positioned by one person from inside the building by means of rope and pulley after the trailer is in position. The resilient foam pads can be covered with a large selection of tough abrasion resistant fabric, creating a tight seal that blocks foul weather, insects and dust, while saving money on energy costs. The series 0201 Dock Seal will also protect personnel, product and equipment while increasing comfort, safety and productivity.

SUPER SEAL

Tel: 905.850.2929 Tel: 1.800.337.3239
Fax: 905.850.2922 Fax: 905.850.4440

www.supersealmfg.com

SuperSeal Mfg. Ltd.
670 Rowntree Dairy Rd.,
Woodbridge, Ontario, Canada L4L 5T8

SPECIFICATIONS

Series 0201 Product Details:

- Series 0201 standard dimensions for door openings 8' W. x 10' H. has (2) two 10' high vertical pads with a 12" face, wedge shape and (1) one 10' long head curtain with a 24" drop. Unit projection to be 10".
- Seals trailer(s) 12' to 13'6" H. from grade with a dock height of 48".
- A large selection of cover fabrics available including our exclusive SS-90-1 high performance vinyl. Other available fabrics include hypalon and other vinyls. (SEE MATERIAL SELECTION GUIDE).
- Can be fitted for openings up to 10' W. x 12' H. by the use of wedge shaped verticals and longer curtain.
- 4" - 6" pad projection in front of the dock bumper face is recommended to prevent over-compression, excessive wear & tear and undue building wall pressure.

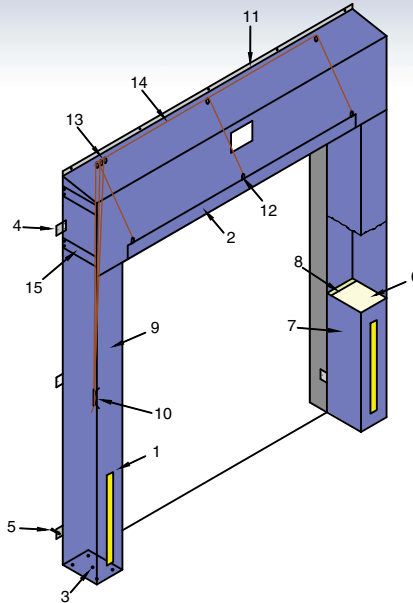

1. Vertical pad
2. Adjustable head curtain
3. Air vents
4. Galvanized steel mounting brackets
5. Sleeve anchor bolts
6. Polyurethane foam core
7. Cover fabric
8. Pressure treated wood backing
9. 4" wide yellow guide stripe
10. Rope cleat
11. Head curtain retaining bar
12. "D" rings
13. Pulleys
14. Rope
15. Head curtain restraining straps

Specifications:

Dock door seal(s) to be **Series 0201** as manufactured by Super Seal Mfg. Ltd., Woodbrige, Ontario. Dock door seal(s) to be manufactured to fit door opening size _____ ft. wide x _____ ft. high. Vertical pads to be manufactured using kiln-dried wood and high grade, dense, light weight urethane foam core with 98% copression recovery and maintaining flexibility at -40° (fire retardant formula available; please specify). Foam core shall be continously bonded (not spot glued) to the wood backing with a industrial, non-flammable elastic adhesive. Cover fabric shall be double stitched with high strength twisted 4 ply 100% polyester bonded, U.V. treated thread. Cover fabric overlaps wood backing totally enclosing it and fastened with heavy duty plated staples. Vertical pads are vented through brass plated grommets allowing air to be exhausted and moisture to drain. Vertical pads are tapered cut at top to provide adequate drainage. Vertical pads have a 24" high 4" wide yellow guide stripe to aid in visibility. Unit shall come complete with a droop curtain over vertical pads. Full width steel tube shall be inserted into a pocket on the head curtain to prevent sagging. Curtain is manually adjusted by means of rope and pulley assembly. Unit shall be furnished with galvanized mounting hardware to resist corrosion.

Options:

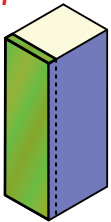

A. Cover Material overlaps edges only

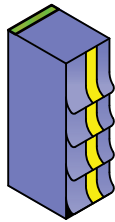

B. Protective flaps (4", 8" & 16" exposure)

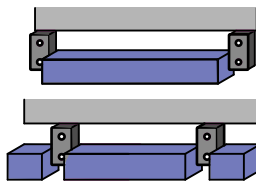

C. Bottom seal

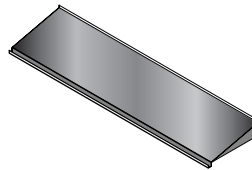

D. Galvanized steel canopy

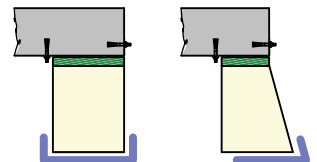

E. Double layer on impact area

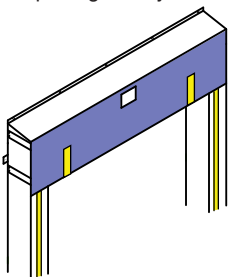

F. Split curtain

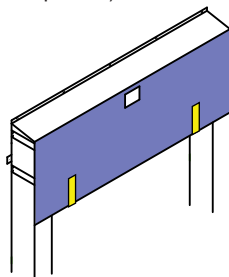

G. Longer drop curtain

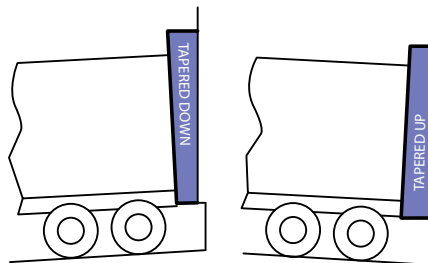

H. Tapered units

- I. Beveled Vertical pads
MODELS
 8/11
 12/15
 12/18
 8/20



DEALER IMPRINT



** All Super Seal products are subject to design modifications without notice. Product may be shown with non-standard options.